

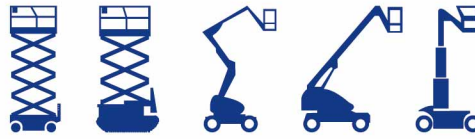

中国高空作业机械制造商 10 强
CHINA TOP 10 MOBILE ELEVATING WORK PLATFORM



lift platform



山东嘉峰重工机械有限公司

Shandong Chufeng Heavy Industry Machinery Co., Ltd.

☎ +86-13256139678(WeChat/Whatsapp/微信同号)

🌐 www.cncfmglift.com

✉ sales1@cfmglift.com

📍 中国山东省济南市回河街道滨河街7号
No.7 Binhe Street, Huihe Street, Jinan, Shandong, China



实力厂家 品质保障

QUALITY ASSURANCE FROM STRONG MANUFACTURERS





公司简介 Company Profile

山东嘉峰重工机械有限公司始创于 2008 年，发源于“中国液压升降平台之乡”——山东济阳，是以全自动高空作业平台研发、制造、销售为主导，并提供全套设备售后服务综合解决方案的创新实体企业，是中国高空作业平台制造商 10 强、全球高空作业机械制造商 20 强企业。

2019 年公司获得“国家高新技术企业”、“瞪羚企业”和“泉城产业领军人才”企业荣誉称号，同期迈入中国工程机械专业化制造商 50 强行列。

2020 年荣获市级“专精特新”中小企业荣誉称号，加入济南（国际）机器人与高端装备产业联盟，成为济南市机器人与高端装备协会会员。

2021 年全体职工团结拼搏荣获济南市“工人先锋号”和山东省“专精特新”中小企业荣誉称号。

2022 年荣获山东省“工人先锋号”、济南市“绿色工厂”荣誉称号，济南市智能制造试点示范项目企业。

公司经过长期的研究和探索，积累了丰富的高空作业平台制造经验，创造了高品质的产品，目前已受理 2 项国家发明专利、授权 23 项实用新型专利、20 项外观专利、4 项软件著作权，通过了 ISO 四体系认证、CE 欧盟认证、3A 诚信企业认证，产品由中国人民保险公司承保，从工程设计、采购、装配直到测试，最终审核确认，嘉峰重工一直高度关注每一个阶段的产品品质、服务于可靠性。无论您身在何处都能感受我们专业技术人员快捷优质的服务，我们将以优质的产品和满意的服务回馈社会。

嘉峰重工，助您成功！

Shandong Chufeng Heavy Industry Machinery Co., Ltd. was founded in 2008 and was founded in Jiyang, Shandong, the "hometown of hydraulic lifting platforms in China". It is an innovative entity led by the research and development, manufacturing, and sales of fully automatic high-altitude work platforms, and provides comprehensive solutions for equipment after-sales services. It is one of the top 10 high-altitude work platform manufacturers in China and one of the top 20 global high-altitude work machinery manufacturers.

In 2019, the company was awarded the honorary titles of "National High tech Enterprise", "Gazelle Enterprise", and "Quancheng Industry Leading Talent". During the same period, it entered the mandatory list of 50 Chinese construction machinery specialized manufacturers.

In 2020, it won the honorary title of "specialized, special and new" small and medium-sized enterprises at the municipal level, joined the Jinan (international) Robot and High end Equipment Industry Alliance, and became a member of the robot and High end Equipment Association of Jinan.

In 2021, all employees worked together and won the honorary titles of "Worker Pioneer" in Jinan City and "Specialized, Refined, and New" Small and Medium Enterprises in Shandong Province.

In 2022, it was awarded the honorary titles of "Worker Pioneer" in Shandong Province and "Green Factory" in Jinan City, and was a pilot demonstration project enterprise for intelligent manufacturing in Jinan City.

After long-term research and exploration, the company has accumulated rich experience in manufacturing high-altitude work platforms and created high-quality products. Currently, it has accepted 2 national invention patents, authorized 23 utility model patents, 20 appearance patents, and 4 software copyrights. It has passed ISO four system certification, CE EU certification, and 3A integrity enterprise certification. The products are underwritten by the People's Insurance Company of China, covering engineering design, procurement, assembly, and testing, The final review confirms that Jiafeng Heavy Industry has always been highly concerned about product quality, service and reliability at each stage. No matter where you are, you can feel the fast and high-quality service of our professional technicians. We will give back to society with high-quality products and satisfactory services.

Chufeng Heavy Industry, helping you succeed!

工业化流水作业车间-品质值得信赖

INDUSTRIALIZED ASSEMBLY LINE WORKSHOP - TRUSTWORTHY QUALITY



硅烷电泳喷塑流水线 Silane Electrophoretic Spray Molding Assembly Line

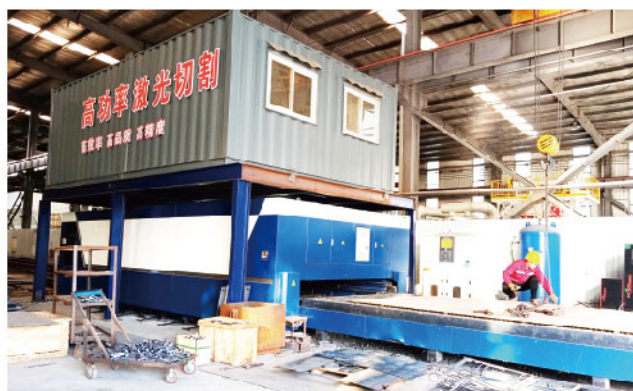

12000W激光切割设备
12000 W Laser Cutting Equipment



矩管激光切割设备
Rectangular Tube Laser Cutting Equipment



机器人焊接设备
Robot Welding Equipment



荣誉证书—多年来我们始终在进步

HONORARY CERTIFICATE - WE HAVE BEEN MAKING PROGRESS FOR MANY YEARS





产 / 品 / 系 / 列

PRODUCT CENTER



小型自行走剪叉式高空作业平台系列
MINI SELF-PROPELLED SCISSORS
LIFT PLATFORM SERIES
3.9M/4.5M

- 举升比例阀控制, 精准灵活
Lift proportional valve control, precise and flexible
- 易损电气件IP67级防水
Vulnerable electrical components IP67 waterproof



小型履带剪叉式高空作业平台
MINI CRAWLER SCISSORS
LIFT PLATFORM
4.5M

- 可进电梯等狭窄空间
Access to narrow spaces such as elevators
- 无痕履带, 减少对地面的摩擦
Trackless tracks reduce friction on the ground



自行走剪叉式高空作业平台系列
SELF-PROPELLED SCISSORS
LIFT PLATFORM SERIES
5.8M/6M/8M/10M/11.8M/13.7M

- 智能化人机交互系统
Intelligent human-machine interaction system
- 电池供能, 液压驱动
Battery powered, hydraulically driven
- 电泳+喷粉工艺
Electrophoresis+powder spraying process



履带剪叉式高空作业平台系列
CRAWLER SCISSORS
LIFT PLATFORM SERIES
6M/8M/10M

- 可以原地旋转, 零内转弯半径
Can rotate in place with zero internal turning radius
- 大功率交流电机, 越野能力强
High power AC motor with strong off-road capability
- 整体抽屉式托盘, 方便维修
Integrated drawer tray for easy maintenance



支腿履带剪叉式高空作业平台系列
CRAWLER SCISSORS
LIFT PLATFORM SERIES WITH OUTRIGGER
8M/9.75M/11.75M/13.75M

- 液压支腿, 一键调平
Hydraulic support legs, one click leveling
- 大功率交流电机
High power AC motor with strong off-road capability



CROSS-COUNTRY
越野剪叉式高空作业平台系列
CROSS-COUNTRY SCISSORS
LIFT PLATFORM SERIES
12M/16M

- 大马力柴油发动机
High horsepower diesel engine
- 配置称重传感器
Configure load cells



STEEL
履带剪叉式高空作业平台系列
CRAWLER SCISSORS
LIFT PLATFORM SERIES
6M/8M/10M

- 电池电压预警功能
Battery voltage warning function
- 电池续航能力强
Strong battery life
- 钢制履带, 越障能力优越
Steel track with superior obstacle crossing ability



STEEL
支腿履带剪叉式高空作业平台系列
CRAWLER SCISSORS
LIFT PLATFORM SERIES WITH OUTRIGGER
8M/9.75M/11.75M/13.75M

- 电池续航能力强
Strong battery life
- 可原地转向
Can turn in place
- 适合室外恶劣环境工作
Suitable for working in harsh outdoor environments



CFPT0407DC 3.9M

小型全自行剪叉式升降平台 Mini Self-propelled Scissors Lift Platform

标准配置

- 比例控制
- 平台门自锁
- 单向延伸平台
- 全行程行走
- 无痕轮胎
- 4X2驱动
- 自动刹车系统
- 紧急下降系统
- 紧急停止按钮
- 油管防爆系统
- 故障诊断系统
- 倾斜保护系统
- 动作蜂鸣器
- 喇叭
- 工作时间表
- 安全检修支撑
- 标准运输叉车孔
- 充电保护系统
- 频闪灯
- 折叠围栏

Standard Configuration

- Proportional Control
- Self-Lock Gate On Platform
- Extension Platform
- Full Height Walking
- Non-Marking Tire
- 4x2 Drive
- Automatic Brake System
- Emergency Descent System
- Emergency Stop Button
- Oil Pipe Explosion-Proof System
- Fault Diagnosis System
- Tilt Protection System
- Buzzer
- Horn
- Hour Meter
- Safety Maintenance Support
- Standard Transport Forklift Hole
- Charging Protection System
- Strobe Lamp
- Foldable Guardrail

选配配置

- 超载限制
- 底盘到平台AC电源
- 平台工作灯
- 底盘到平台导气管
- 平台防撞头开关

Optional Configuration

- Overload Sensor With Alarm
- AC Power On The Platform
- Platform Work Light
- Chassis To Platform Air Duct
- Top Limit Protection





5分钟响应答复
Response
Within 5-Minute



24小时内解决问题
Resolve Issues
Within 24Hours



48小时内发送配件
Send Parts
Within 48Hours

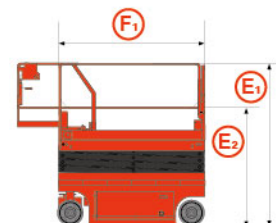
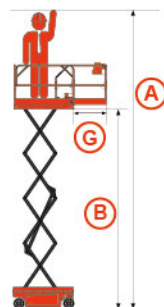

CFPT04070C

产品参数 Product Parameters

安全工作载荷 Load Capacity	240Kg	(A)	最小转弯半径 Turning Radius	0mm
最大工作高度 Max. working Height	5.9m	(B)	机器运行速度(收拢) Machine Running Speed (Stowed)	4Km/h
最大平台高度 Max. platform Height	3.9m		机器运行速度(起升) Machine Running Speed (Raised)	0.5Km/h
整机长度 Overall Length	1320mm		最小离地间隙 Ground Clearance	50mm
整机宽度 Overall Width	760mm	(D)	轮胎 Tyre	Φ230×80mm
整机高度(护栏未折叠/折叠) Overall Height (Guardrail Unfolded/folded)	1940/1590mm	(E1) × (E2)	起升电机 Lifting Motor	24V/0.8Kw
工作平台尺寸(长×宽) Platform Size(Length×Wide)	1150×700mm	(F1) × (F2)	蓄电池 Batteries	2×12V/80Ah
平台延伸尺寸 Platform Exsension	550mm	(G)	充电器 Charger	24V/12A
最大爬坡能力 Gradeability	25%		整机重量 Weight	688Kg



CFPT0408DC 4.5M

全自行剪叉式升降平台 Self-propelled Scissors Lift Platform

标准配置

- 比例控制
- 平台门自锁
- 单向延伸平台
- 全行程行走
- 无痕轮胎
- 4X2驱动
- 自动刹车系统
- 紧急下降系统
- 紧急停止按钮
- 油管防爆系统
- 故障诊断系统
- 倾斜保护系统
- 动作蜂鸣器
- 喇叭
- 工作时间表
- 安全检修支撑
- 标准运输叉车孔
- 充电保护系统
- 频闪灯
- 折叠围栏
- 自动坑洞保护

Standard Configuration

- Proportional Control
- Self-Lock Gate On Platform
- Extension Platform
- Full Height Walking
- Non-Marking Tire
- 4x2 Drive
- Automatic Brake System
- Emergency Descent System
- Emergency Stop Button
- Oil Pipe Explosion-Proof System
- Fault Diagnosis System
- Tilt Protection System
- Buzzer
- Horn
- Hour Meter
- Safety Maintenance Support
- Standard Transport Forklift Hole
- Charging Protection System
- Strobe Lamp
- Foldable Guardrail
- Automatic Pit Protection

选配配置

- 超载限制
- 底盘到平台AC电源
- 平台工作灯
- 底盘到平台导气管
- 平台防碰头开关

Optional Configuration

- Overload Limit
- AC Power On the Platform
- Platform Work Light
- Chassis To Platform Air Duct
- Top Limit Protection





5分钟响应答复
Response
Within 5-Minute



24小时内解决问题
Resolve Issues
Within 24Hours



48小时内发送配件
Send Parts
Within 48Hours

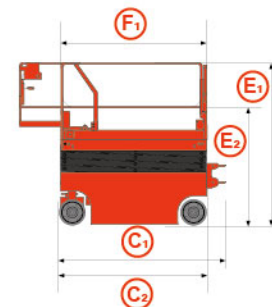
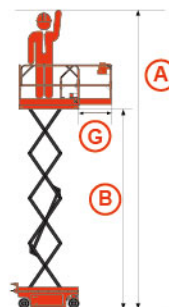

CFPT0408DC

产品参数 Product Parameters

安全工作载荷 Load Capacity	240Kg	轴距 Wheelbase	1130mm
延伸平台安全工作载荷 Load Capacity Of Extended Platform	100Kg	最小转弯半径(内/外轮) Min. Turning Radius (Inner/Outer Wheel)	0/1.6m
最大工作人数 Max. Number Of Workers	2	起升电机 Lifting Motor	24V/1.2Kw
最大工作高度 Working Height	6.5m (A)	机器运行速度(收拢/起升) Machine Running Speed (Stowed/Raised)	4.5/0.8Km/h
最大平台高度 Max. Platform Height	4.5m (B)	上升/下降速度 Rising/Descending Speed	20/15sec
整机长度(带梯子) Overall Length (With Ladder)(Fold/Unfold)	1445mm/1540mm (C ₁)	蓄电池 Batteries	2×12V/100Ah
整机长度(不带梯子) Overall Length (Without Ladder)	1440mm (C ₂)	充电器 Charger	24V/15A
整机宽度 Overall Width	810mm (D)	最大爬坡能力 Gradeability	25%
整机高度(护栏未折叠/折叠) Overall Height (Guardrail Unfolded/Folded)	2148/1790mm (E ₁ × E ₂)	工作最大允许角度 Max. Working Slope	1.5°/3°
工作平台尺寸(长×宽) Platform Size(Length × Wide)	1355×700mm (F ₁ × F ₂)	轮胎 Tyre	Φ305×100mm
平台延伸尺寸 Platform Extension Size	600mm (G)	液压油箱容积 Hydraulic Oil Tank	4L
最小离地间隙(收拢状态/起升状态) Min. Ground Clearance (Stowed/Raised)	75/17mm	整机重量 Overall Weight	990Kg



CFPT0608DC 5.6M

全自行剪叉式升降平台 Self-propelled Scissors Lift Platform

标准配置

- 比例控制
- 平台门自锁
- 单向延伸平台
- 全行程行走
- 无痕轮胎
- 4X2驱动
- 自动刹车系统
- 紧急下降系统
- 紧急停止按钮
- 油管防爆系统
- 故障诊断系统
- 倾斜保护系统
- 动作蜂鸣器
- 喇叭
- 工作时间表
- 安全检修支撑
- 标准运输叉车孔
- 充电保护系统
- 频闪灯
- 折叠围栏
- 自动坑洞保护

Standard Configuration

- Proportional Control
- Self-Lock Gate On Platform
- Extension Platform
- Full Height Walking
- Non-Marking Tire
- 4x2 Drive
- Automatic Brake System
- Emergency Descent System
- Emergency Stop Button
- Oil Pipe Explosion-Proof System
- Fault Diagnosis System
- Tilt Protection System
- Buzzer
- Horn
- Hour Meter
- Safety Maintenance Support
- Standard Transport Forklift Hole
- Charging Protection System
- Strobe Lamp
- Foldable Guardrail
- Automatic Pit Protection

选配配置

- 超载限制
- 底盘到平台AC电源
- 平台工作灯
- 底盘到平台导气管
- 平台防碰头开关

Optional Configuration

- Overload Limit
- AC Power On the Platform
- Platform Work Light
- Chassis To Platform Air Duct
- Top Limit Protection





5分钟响应答复
Response
Within 5-Minute



24小时内解决问题
Resolve Issues
Within 24Hours



48小时内发送配件
Send Parts
Within 48Hours

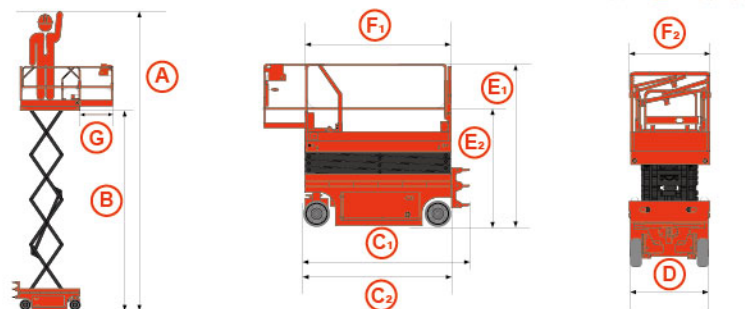

CFPT0608DC

产品参数 Product Parameters

安全工作载荷 Load Capacity	240Kg	轴距 Wheelbase	1130mm
延伸平台安全工作载荷 Load Capacity Of Extended Platform	100Kg	最小转弯半径(内/外轮) Min. Turning Radius (Inner/Outer Wheel)	0/1.6m
最大工作人数 Max. Number Of Workers	2	起升电机 Lifting Motor	24V/1.2Kw
最大工作高度 Working Height	7.6m (A)	机器运行速度(收拢/起升) Machine Running Speed (Stowed/Raised)	4.5/0.8Km/h
最大平台高度 Max. Platform Height	5.6m (B)	上升/下降速度 Rising/Descending Speed	25/20sec
整机长度(带梯子) Overall Length (With Ladder)	1540mm (C ₁)	蓄电池 Batteries	2×12V/100Ah
整机长度(不带梯子) Overall Length (Without Ladder)	1440mm (C ₂)	充电器 Charger	24V/15A
整机宽度 Overall Width	810mm (D)	最大爬坡能力 Gradeability	25%
整机高度(护栏未折叠/折叠) Overall Height (Guardrail Unfolded/Folded)	2195/1830mm (E ₁ × E ₂)	工作最大允许角度 Max. Working Slope	1.5°/3°
工作平台尺寸(长×宽) Platform Size(Length × Wide)	1370×700mm (F ₁ × F ₂)	轮胎 Tyre	Φ305×100mm
平台延伸尺寸 Platform Extension Size	600mm (G)	液压油箱容积 Hydraulic Oil Tank	4L
最小离地间隙(收拢状态/起升状态) Min. Ground Clearance (Stowed/Raised)	67/17mm	整机重量 Overall Weight	1260Kg



CFPT0608SP 5.8M

全自行剪叉式升降平台 Self-propelled Scissors Lift Platform

标准配置

- 比例控制
- 平台门自锁
- 单向延伸平台
- 全行程行走
- 无痕轮胎
- 4X2驱动
- 自动刹车系统
- 紧急下降系统
- 紧急停止按钮
- 油管防爆系统
- 故障诊断系统
- 倾斜保护系统
- 动作蜂鸣器
- 喇叭
- 工作时间表
- 安全检修支撑
- 标准运输叉车孔
- 充电保护系统
- 频闪灯
- 折叠围栏
- 自动坑洞保护

Standard Configuration

- Proportional Control
- Self-Lock Gate On Platform
- Extension Platform
- Full Height Walking
- Non-Marking Tire
- 4x2 Drive
- Automatic Brake System
- Emergency Descent System
- Emergency Stop Button
- Oil Pipe Explosion-Proof System
- Fault Diagnosis System
- Tilt Protection System
- Buzzer
- Horn
- Hour Meter
- Safety Maintenance Support
- Standard Transport Forklift Hole
- Charging Protection System
- Strobe Lamp
- Foldable Guardrail
- Automatic Pit Protection

选配配置

- 超载限制
- 底盘到平台AC电源
- 平台工作灯
- 底盘到平台导气管
- 平台防碰头开关

Optional Configuration

- Overload Limit
- AC Power On the Platform
- Platform Work Light
- Chassis To Platform Air Duct
- Top Limit Protection





5分钟响应答复
Response
Within 5-Minute



24小时内解决问题
Resolve Issues
Within 24Hours



48小时内发送配件
Send Parts
Within 48Hours

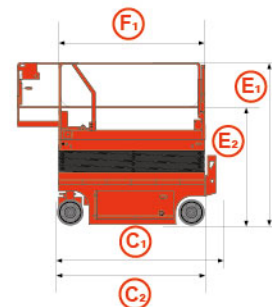
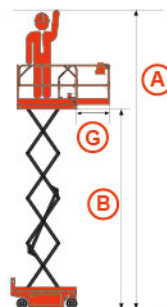

CFPT0608SP

产品参数 Product Parameters

安全工作载荷 Load Capacity	230Kg	轴距 Wheelbase	1355mm
延伸平台安全工作载荷 Load Capacity Of Extended Platform	113Kg	最小转弯半径(内/外轮) Min. Turning Radius (Inner/Outer Wheel)	0/1.64m
最大工作人数 Max. Number Of Workers	2	起升电机 Lifting Motor	24V/4.5Kw
最大工作高度 Working Height	7.8m (A)	机器运行速度(收拢/起升) Machine Running Speed (Stowed/Raised)	3/0.8Km/h
最大平台高度 Max. Platform Height	5.8m (B)	上升/下降速度 Rising/Descending Speed	25/20sec
整机长度(带梯子) Overall Length (With Ladder)	1860mm (C ₁)	蓄电池 Batteries	4×6V/210Ah
整机长度(不带梯子) Overall Length (Without Ladder)	1687mm (C ₂)	充电器 Charger	24V/30A
整机宽度 Overall Width	763mm (D)	最大爬坡能力 Gradeability	25%
整机高度(护栏未折叠/折叠) Overall Height (Guardrail Unfolded/Folded)	2165/1810mm (E ₁ × E ₂)	工作最大允许角度 Max. Working Slope	1.5°/3°
工作平台尺寸(长×宽) Platform Size(Length × Wide)	1670×755mm (F ₁ × F ₂)	轮胎 Tyre	Φ305×100mm
平台延伸尺寸 Platform Extension Size	900mm (G)	液压油箱容积 Hydraulic Oil Tank	8L
最小离地间隙(收拢状态/起升状态) Min. Ground Clearance (Stowed/Raised)	68/20mm	整机重量 Overall Weight	1540Kg



CFPT0608NP 6M

全自行剪叉式升降平台 Self-propelled Scissors Lift Platform

标准配置

- 比例控制
- 平台门自锁
- 单向延伸平台
- 全行程行走
- 无痕轮胎
- 4X2驱动
- 自动刹车系统
- 紧急下降系统
- 紧急停止按钮
- 油管防爆系统
- 故障诊断系统
- 倾斜保护系统
- 动作蜂鸣器
- 喇叭
- 工作时间表
- 安全检修支撑
- 标准运输叉车孔
- 充电保护系统
- 频闪灯
- 折叠围栏
- 自动坑洞保护

Standard Configuration

- Proportional Control
- Self-Lock Gate On Platform
- Extension Platform
- Full Height Walking
- Non-Marking Tire
- 4x2 Drive
- Automatic Brake System
- Emergency Descent System
- Emergency Stop Button
- Oil Pipe Explosion-Proof System
- Fault Diagnosis System
- Tilt Protection System
- Buzzer
- Horn
- Hour Meter
- Safety Maintenance Support
- Standard Transport Forklift Hole
- Charging Protection System
- Strobe Lamp
- Foldable Guardrail
- Automatic Pit Protection

选配配置

- 超载限制
- 底盘到平台AC电源
- 平台工作灯
- 底盘到平台导气管
- 平台防碰头开关

Optional Configuration

- Overload Limit
- AC Power On the Platform
- Platform Work Light
- Chassis To Platform Air Duct
- Top Limit Protection





5分钟响应答复
Response
Within 5-Minute



24小时内解决问题
Resolve Issues
Within 24Hours



48小时内发送配件
Send Parts
Within 48Hours

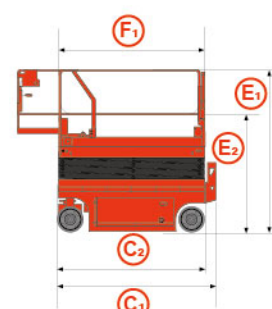
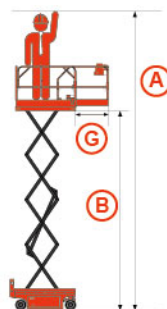

CFPT0608NP

产品参数 Product Parameters

安全工作载荷 Load Capacity	380Kg	轴距 Wheelbase	1865mm
延伸平台安全工作载荷 Load Capacity Of Extended Platform	113Kg	最小转弯半径(内/外轮) Min. Turning Radius (Inner/Outer Wheel)	0/2.2m
最大工作人数 Max. Number Of Workers	2	起升电机 Lifting Motor	24V/4.5Kw
最大工作高度 Working Height	8m (A)	机器运行速度(收拢/起升) Machine Running Speed (Stowed/Raised)	3/0.8Km/h
最大平台高度 Max. Platform Height	6m (B)	上升/下降速度 Rising/Descending Speed	35/30sec
整机长度(带梯子) Overall Length (With Ladder)	2485mm (C ₁)	蓄电池 Batteries	4×6V/210Ah
整机长度(不带梯子) Overall Length (Without Ladder)	2280mm (C ₂)	充电器 Charger	24V/30A
整机宽度 Overall Width	820mm (D)	最大爬坡能力 Gradeability	25%
整机高度(护栏未折叠/折叠) Overall Height (Guardrail Unfolded/Folded)	2220/1860mm (E ₁ × E ₂)	工作最大允许角度 Max. Working Slope	1.5°/3°
工作平台尺寸(长×宽) Platform Size (Length × Wide)	2270×810mm (F ₁ × F ₂)	轮胎 Tyre	Φ381×127mm
平台延伸尺寸 Platform Extension Size	900mm (G)	液压油箱容积 Hydraulic Oil Tank	20L
最小离地间隙(收拢状态/起升状态) Min. Ground Clearance (Stowed/Raised)	100/19mm	整机重量 Overall Weight	1820Kg



CFPT0608 6M

全自行剪叉式升降平台 Self-propelled Scissors Lift Platform

标准配置

- 比例控制
- 平台门自锁
- 单向延伸平台
- 全行程行走
- 无痕轮胎
- 4X2驱动
- 自动刹车系统
- 紧急下降系统
- 紧急停止按钮
- 油管防爆系统
- 故障诊断系统
- 倾斜保护系统
- 动作蜂鸣器
- 喇叭
- 工作时间表
- 安全检修支撑
- 标准运输叉车孔
- 充电保护系统
- 频闪灯
- 折叠围栏
- 自动坑洞保护

Standard Configuration

- Proportional Control
- Self-Lock Gate On Platform
- Extension Platform
- Full Height Walking
- Non-Marking Tire
- 4x2 Drive
- Automatic Brake System
- Emergency Descent System
- Emergency Stop Button
- Oil Pipe Explosion-Proof System
- Fault Diagnosis System
- Tilt Protection System
- Buzzer
- Horn
- Hour Meter
- Safety Maintenance Support
- Standard Transport Forklift Hole
- Charging Protection System
- Strobe Lamp
- Foldable Guardrail
- Automatic Pit Protection

选配配置

- 超载限制
- 底盘到平台AC电源
- 平台工作灯
- 底盘到平台导气管
- 平台防碰头开关

Optional Configuration

- Overload Limit
- AC Power On the Platform
- Platform Work Light
- Chassis To Platform Air Duct
- Top Limit Protection





5分钟响应答复
Response
Within 5-Minute



24小时内解决问题
Resolve Issues
Within 24Hours



48小时内发送配件
Send Parts
Within 48Hours

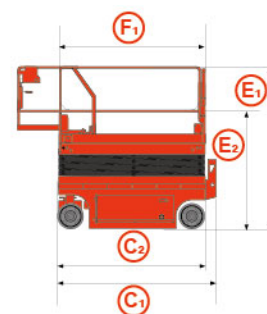
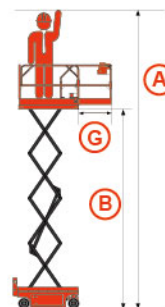

CFPT0608

产品参数 Product Parameters

安全工作载荷 Load Capacity	450Kg	轴距 Wheelbase	1865mm
延伸平台安全工作载荷 Load Capacity Of Extended Platform	113Kg	最小转弯半径(内/外轮) Min. Turning Radius (Inner/Outer Wheel)	0/2.2m
最大工作人数 Max. Number Of Workers	2	起升电机 Lifting Motor	24V/4.5Kw
最大工作高度 Working Height	8m (A)	机器运行速度(收拢/起升) Machine Running Speed (Stowed/Raised)	3/0.8Km/h
最大平台高度 Max. Platform Height	6m (B)	上升/下降速度 Rising/Descending Speed	35/30sec
整机长度(带梯子) Overall Length (With Ladder)	2485mm (C ₁)	蓄电池 Batteries	4×6V/230Ah
整机长度(不带梯子) Overall Length (Without Ladder)	2280mm (C ₂)	充电器 Charger	24V/30A
整机宽度 Overall Width	1210mm (D)	最大爬坡能力 Gradeability	25%
整机高度(护栏未折叠/折叠) Overall Height (Guardrail Unfolded/Folded)	2235/1680mm (E ₁ × E ₂)	工作最大允许角度 Max. Working Slope	1.5°/3°
工作平台尺寸(长×宽) Platform Size (Length × Wide)	2270×1110mm (F ₁ × F ₂)	轮胎 Tyre	Φ381×127mm
平台延伸尺寸 Platform Extension Size	900mm (G)	液压油箱容积 Hydraulic Oil Tank	20L
最小离地间隙(收拢状态/起升状态) Min. Ground Clearance (Stowed/Raised)	100/19mm	整机重量 Overall Weight	2070Kg



CFPT0810NP 8M

全自行剪叉式升降平台 Self-propelled Scissors Lift Platform

标准配置

- 比例控制
- 平台门自锁
- 单向延伸平台
- 全行程行走
- 无痕轮胎
- 4X2驱动
- 自动刹车系统
- 紧急下降系统
- 紧急停止按钮
- 油管防爆系统
- 故障诊断系统
- 倾斜保护系统
- 动作蜂鸣器
- 喇叭
- 工作时间表
- 安全检修支撑
- 标准运输叉车孔
- 充电保护系统
- 频闪灯
- 折叠围栏
- 自动坑洞保护

Standard Configuration

- Proportional Control
- Self-Lock Gate On Platform
- Extension Platform
- Full Height Walking
- Non-Marking Tire
- 4x2 Drive
- Automatic Brake System
- Emergency Descent System
- Emergency Stop Button
- Oil Pipe Explosion-Proof System
- Fault Diagnosis System
- Tilt Protection System
- Buzzer
- Horn
- Hour Meter
- Safety Maintenance Support
- Standard Transport Forklift Hole
- Charging Protection System
- Strobe Lamp
- Foldable Guardrail
- Automatic Pit Protection

选配配置

- 超载限制
- 底盘到平台AC电源
- 平台工作灯
- 底盘到平台导气管
- 平台防碰头开关

Optional Configuration

- Overload Limit
- AC Power On the Platform
- Platform Work Light
- Chassis To Platform Air Duct
- Platform Anti Collision Switch





5分钟响应答复
Response
Within 5-Minute



24小时内解决问题
Resolve Issues
Within 24Hours



48小时内发送配件
Send Parts
Within 48Hours

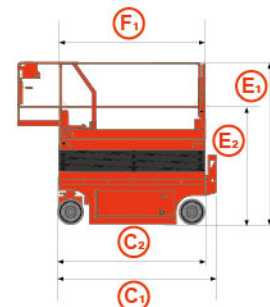
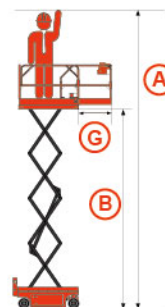

CFPT0810NP

产品参数 Product Parameters

安全工作载荷 Load Capacity	230Kg	轴距 Wheelbase	1865mm
延伸平台安全工作载荷 Load Capacity Of Extended Platform	113Kg	最小转弯半径(内/外轮) Min. Turning Radius (Inner/Outer Wheel)	0/2.2m
最大工作人数 Max. Number Of Workers	2	起升电机 Lifting Motor	24V/4.5Kw
最大工作高度 Working Height	10m (A)	机器运行速度(收拢/起升) Machine Running Speed (Stowed/Raised)	3/0.8Km/h
最大平台高度 Max. Platform Height	8m (B)	上升/下降速度 Rising/Descending Speed	38/40sec
整机长度(带梯子) Overall Length (With Ladder)	2492mm (C ₁)	蓄电池 Batteries	4×6V/230Ah
整机长度(不带梯子) Overall Length (Without Ladder)	2280mm (C ₂)	充电器 Charger	24V/30A
整机宽度 Overall Width	820mm (D)	最大爬坡能力 Gradeability	25%
整机高度(护栏未折叠/折叠) Overall Height (Guardrail Unfolded/Folded)	2357/1985mm (E ₁ × E ₂)	工作最大允许角度 Max. Working Slope	1.5°/3°
工作平台尺寸(长×宽) Platform Size (Length × Wide)	2270×810mm (F ₁ × F ₂)	轮胎 Tyre	Φ381×127mm
平台延伸尺寸 Platform Extension Size	900mm (G)	液压油箱容积 Hydraulic Oil Tank	20L
最小离地间隙(收拢状态/起升状态) Min. Ground Clearance (Stowed/Raised)	100/19mm	整机重量 Overall Weight	1970Kg



CFPT0810 8M

全自行剪叉式升降平台 Self-propelled Scissors Lift Platform

标准配置

- 比例控制
- 平台门自锁
- 单向延伸平台
- 全行程行走
- 无痕轮胎
- 4X2驱动
- 自动刹车系统
- 紧急下降系统
- 紧急停止按钮
- 油管防爆系统
- 故障诊断系统
- 倾斜保护系统
- 动作蜂鸣器
- 喇叭
- 工作时间表
- 安全检修支撑
- 标准运输叉车孔
- 充电保护系统
- 频闪灯
- 折叠围栏
- 自动坑洞保护

Standard Configuration

- Proportional Control
- Self-Lock Gate On Platform
- Extension Platform
- Full Height Walking
- Non-Marking Tire
- 4x2 Drive
- Automatic Brake System
- Emergency Descent System
- Emergency Stop Button
- Oil Pipe Explosion-Proof System
- Fault Diagnosis System
- Tilt Protection System
- Buzzer
- Horn
- Hour Meter
- Safety Maintenance Support
- Standard Transport Forklift Hole
- Charging Protection System
- Strobe Lamp
- Foldable Guardrail
- Automatic Pit Protection

选配配置

- 超载限制
- 底盘到平台AC电源
- 平台工作灯
- 底盘到平台导气管
- 平台防碰头开关

Optional Configuration

- Overload Limit
- AC Power On the Platform
- Platform Work Light
- Chassis To Platform Air Duct
- Top Limit Protection





5分钟响应答复
Response
Within 5-Minute



24小时内解决问题
Resolve Issues
Within 24Hours



48小时内发送配件
Send Parts
Within 48Hours

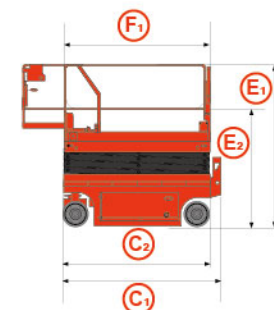
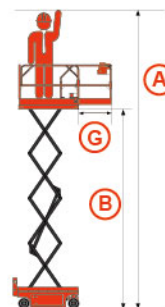

CFPT0810

产品参数 Product Parameters

安全工作载荷 Load Capacity	450Kg	轴距 Wheelbase	1865mm
延伸平台安全工作载荷 Load Capacity Of Extended Platform	113Kg	最小转弯半径(内/外轮) Min. Turning Radius (Inner/Outer Wheel)	0/2.2m
最大工作人数 Max. Number Of Workers	2	起升电机 Lifting Motor	24V/4.5Kw
最大工作高度 Working Height	10m (A)	机器运行速度(收拢/起升) Machine Running Speed (Stowed/Raised)	3/0.8Km/h
最大平台高度 Max. Platform Height	8m (B)	上升/下降速度 Rising/Descending Speed	40/35sec
整机长度(带梯子) Overall Length (With Ladder)	2485mm (C ₁)	蓄电池 Batteries	4×6V/248Ah
整机长度(不带梯子) Overall Length (Without Ladder)	2280mm (C ₂)	充电器 Charger	24V/30A
整机宽度 Overall Width	1210mm (D)	最大爬坡能力 Gradeability	25%
整机高度(护栏未折叠/折叠) Overall Height (Guardrail Unfolded/Folded)	2355/1800mm (E ₁ × E ₂)	工作最大允许角度 Max. Working Slope	1.5°/3°
工作平台尺寸(长×宽) Platform Size (Length × Wide)	2270×1110mm (F ₁ × F ₂)	轮胎 Tyre	Φ381×127mm
平台延伸尺寸 Platform Extension Size	900mm (G)	液压油箱容积 Hydraulic Oil Tank	20L
最小离地间隙(收拢状态/起升状态) Min. Ground Clearance (Stowed/Raised)	100/19mm	整机重量 Overall Weight	2220Kg



CFPT1012 10M

全自行剪叉式升降平台 Self-propelled Scissors Lift Platform

标准配置

- 比例控制
- 平台门自锁
- 单向延伸平台
- 全行程行走
- 无痕轮胎
- 4X2驱动
- 自动刹车系统
- 紧急下降系统
- 紧急停止按钮
- 油管防爆系统
- 故障诊断系统
- 倾斜保护系统
- 动作蜂鸣器
- 喇叭
- 工作时间表
- 安全检修支撑
- 标准运输叉车孔
- 充电保护系统
- 频闪灯
- 折叠围栏
- 自动坑洞保护

Standard Configuration

- Proportional Control
- Self-Lock Gate On Platform
- Extension Platform
- Full Height Walking
- Non-Marking Tire
- 4x2 Drive
- Automatic Brake System
- Emergency Descent System
- Emergency Stop Button
- Oil Pipe Explosion-Proof System
- Fault Diagnosis System
- Tilt Protection System
- Buzzer
- Horn
- Hour Meter
- Safety Maintenance Support
- Standard Transport Forklift Hole
- Charging Protection System
- Strobe Lamp
- Foldable Guardrail
- Automatic Pit Protection

选配配置

- 超载限制
- 底盘到平台AC电源
- 平台工作灯
- 底盘到平台导气管
- 平台防碰头开关

Optional Configuration

- Overload Limit
- AC Power On the Platform
- Platform Work Light
- Chassis To Platform Air Duct
- Top Limit Protection





5分钟响应答复
Response
Within 5-Minute



24小时内解决问题
Resolve Issues
Within 24Hours



48小时内发送配件
Send Parts
Within 48Hours

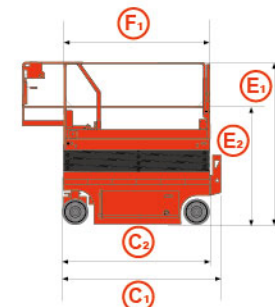
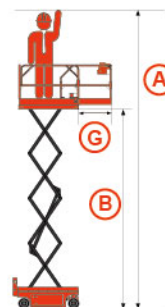

CFPT1012

产品参数 Product Parameters

安全工作载荷 Load Capacity	320Kg	轴距 Wheelbase	1865mm
延伸平台安全工作载荷 Load Capacity Of Extended Platform	113Kg	最小转弯半径(内/外轮) Min. Turning Radius (Inner/Outer Wheel)	0/2.2m
最大工作人数 Max. Number Of Workers	2	起升电机 Lifting Motor	24V/4.5Kw
最大工作高度 Working Height	12m (A)	机器运行速度(收拢/起升) Machine Running Speed (Stowed/Raised)	3/0.8Km/h
最大平台高度 Max. Platform Height	10m (B)	上升/下降速度 Rising/Descending Speed	48/40sec
整机长度(带梯子) Overall Length (With Ladder)	2485mm (C ₁)	蓄电池 Batteries	4×6V/248Ah
整机长度(不带梯子) Overall Length (Without Ladder)	2280mm (C ₂)	充电器 Charger	24V/30A
整机宽度 Overall Width	1210mm (D)	最大爬坡能力 Gradeability	25%
整机高度(护栏未折叠/折叠) Overall Height (Guardrail Unfolded/Folded)	2480/1930mm (E ₁ × E ₂)	工作最大允许角度 Max. Working Slope	1.5°/3°
工作平台尺寸(长×宽) Platform Size (Length × Wide)	2270×1110mm (F ₁ × F ₂)	轮胎 Tyre	Φ381×127mm
平台延伸尺寸 Platform Extension Size	900mm (G)	液压油箱容积 Hydraulic Oil Tank	20L
最小离地间隙(收拢状态/起升状态) Min. Ground Clearance (Stowed/Raised)	100/19mm	整机重量 Overall Weight	2932Kg



CFPT1214 12M

全自行剪叉式升降平台 Self-propelled Scissors Lift Platform

标准配置

- 比例控制
- 平台门自锁
- 单向延伸平台
- 全行程行走
- 无痕轮胎
- 4X2驱动
- 自动刹车系统
- 紧急下降系统
- 紧急停止按钮
- 油管防爆系统
- 故障诊断系统
- 倾斜保护系统
- 动作蜂鸣器
- 喇叭
- 工作时间表
- 安全检修支撑
- 标准运输叉车孔
- 充电保护系统
- 频闪灯
- 折叠围栏
- 自动坑洞保护

Standard Configuration

- Proportional Control
- Self-Lock Gate On Platform
- Extension Platform
- Full Height Walking
- Non-Marking Tire
- 4x2 Drive
- Automatic Brake System
- Emergency Descent System
- Emergency Stop Button
- Oil Pipe Explosion-Proof System
- Fault Diagnosis System
- Tilt Protection System
- Buzzer
- Horn
- Hour Meter
- Safety Maintenance Support
- Standard Transport Forklift Hole
- Charging Protection System
- Strobe Lamp
- Foldable Guardrail
- Automatic Pit Protection

选配配置

- 超载限制
- 底盘到平台AC电源
- 平台工作灯
- 底盘到平台导气管
- 平台防碰头开关

Optional Configuration

- Overload Limit
- AC Power On the Platform
- Platform Work Light
- Chassis To Platform Air Duct
- Top Limit Protection





5分钟响应答复
Response
Within 5-Minute



24小时内解决问题
Resolve Issues
Within 24Hours



48小时内发送配件
Send Parts
Within 48Hours

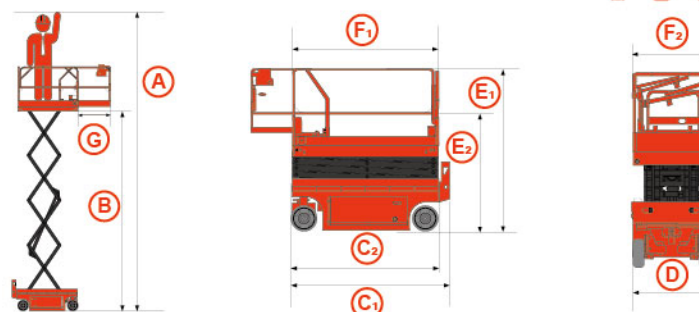

CFPT1214

产品参数 Product Parameters

安全工作载荷 Load Capacity	320Kg	轴距 Wheelbase	1865mm
延伸平台安全工作载荷 Load Capacity Of Extended Platform	113Kg	最小转弯半径(内/外轮) Min. Turning Radius (Inner/Outer Wheel)	0/2.2m
最大工作人数 Max. Number Of Workers	2	起升电机 Lifting Motor	24V/4.5Kw
最大工作高度 Working Height	13.8m (A)	机器运行速度(收拢/起升) Machine Running Speed (Stowed/Raised)	3/0.8Km/h
最大平台高度 Max. Platform Height	11.8m (B)	上升/下降速度 Rising/Descending Speed	58/50sec
整机长度(带梯子) Overall Length (With Ladder)	2485mm (C ₁)	蓄电池 Batteries	4×12V/290Ah
整机长度(不带梯子) Overall Length (Without Ladder)	2280mm (C ₂)	充电器 Charger	24V/30A
整机宽度 Overall Width	1210mm (D)	最大爬坡能力 Gradeability	25%
整机高度(护栏未折叠/折叠) Overall Height (Guardrail Unfolded/Folded)	2613/2060mm (E ₁ × E ₂)	工作最大允许角度 Max. Working Slope	1.5°/3°
工作平台尺寸(长×宽) Platform Size(Length × Wide)	2270×1110mm (F ₁ × F ₂)	轮胎 Tyre	Φ381×127mm
平台延伸尺寸 Platform Extension Size	900mm (G)	液压油箱容积 Hydraulic Oil Tank	20L
最小离地间隙(收拢状态/起升状态) Min. Ground Clearance (Stowed/Raised)	100/19mm	整机重量 Overall Weight	2990Kg



CFPT1416 14M

全自行剪叉式升降平台 Self-propelled Scissors Lift Platform

标准配置

- 比例控制
- 平台门自锁
- 单向延伸平台
- 全行程行走
- 无痕轮胎
- 4×2驱动
- 自动刹车系统
- 紧急下降系统
- 紧急停止按钮
- 油管防爆系统
- 故障诊断系统
- 倾斜保护系统
- 动作蜂鸣器
- 喇叭
- 工作时间表
- 安全检修支撑
- 标准运输叉车孔
- 充电保护系统
- 频闪灯
- 折叠围栏
- 自动坑洞保护

Standard Configuration

- Proportional Control
- Self-Lock Gate On Platform
- Extension Platform
- Full Height Walking
- Non-Marking Tire
- 4x2 Drive
- Automatic Brake System
- Emergency Descent System
- Emergency Stop Button
- Oil Pipe Explosion-Proof System
- Fault Diagnosis System
- Tilt Protection System
- Buzzer
- Horn
- Hour Meter
- Safety Maintenance Support
- Standard Transport Forklift Hole
- Charging Protection System
- Strobe Lamp
- Foldable Guardrail
- Automatic Pit Protection

选配配置

- 超载限制
- 底盘到平台AC电源
- 平台工作灯
- 底盘到平台导气管
- 平台防碰头开关

Optional Configuration

- Overload Limit
- AC Power On the Platform
- Platform Work Light
- Chassis To Platform Air Duct
- Top Limit Protection





5分钟响应答复
Response
Within 5-Minute



24小时内解决问题
Resolve Issues
Within 24Hours



48小时内发送配件
Send Parts
Within 48Hours

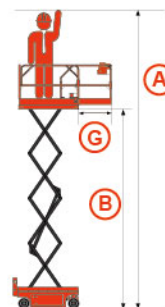

CFPT1416

产品参数 Product Parameters

安全工作载荷 Load Capacity	230Kg	轴距 Wheelbase	2235mm
延伸平台安全工作载荷 Load Capacity Of Extended Platform	113Kg	最小转弯半径(内/外轮) Min. Turning Radius (Inner/Outer Wheel)	0/2.7m
最大工作人数 Max. Number Of Workers	2	起升电机 Lifting Motor	24V/4.5Kw
最大工作高度 Working Height	15.7m (A)	机器运行速度(收拢/起升) Machine Running Speed (Stowed/Raised)	3/0.8Km/h
最大平台高度 Max. Platform Height	13.7m (B)	上升/下降速度 Rising/Descending Speed	68/60sec
整机长度(带梯子) Overall Length (With Ladder)	2860mm (C ₁)	蓄电池 Batteries	4×12V/290Ah
整机长度(不带梯子) Overall Length (Without Ladder)	2640mm (C ₂)	充电器 Charger	24V/30A
整机宽度 Overall Width	1280mm (D)	最大爬坡能力 Gradeability	25%
整机高度(护栏未折叠/折叠) Overall Height (Guardrail Unfolded/Folded)	2660/2100mm (E ₁ × E ₂)	工作最大允许角度 Max. Working Slope	1.5°/3°
工作平台尺寸(长×宽) Platform Size(Length × Wide)	2640×1125mm (F ₁ × F ₂)	轮胎 Tyre	Φ381×127mm
平台延伸尺寸 Platform Extension Size	900mm (G)	液压油箱容积 Hydraulic Oil Tank	30L
最小离地间隙(收拢状态/起升状态) Min. Ground Clearance (Stowed/Raised)	100/19mm	整机重量 Overall Weight	3730Kg



CFPT0407LD 4.5M

小型履带剪叉式升降平台 Mini Crawler Scissors Lift Platform

标准配置

- 比例控制
- 平台门自锁
- 单向延伸平台
- 无痕橡胶履带
- 自动刹车系统
- 紧急下降系统
- 紧急停止按钮
- 油管防爆系统
- 故障诊断系统
- 倾斜保护系统
- 动作蜂鸣器
- 喇叭
- 安全检修支撑
- 标准运输叉车孔
- 充电保护系统
- 频闪灯
- 折叠围栏

Standard Configuration

- Proportional Control
- Self-lock Gate On Platform
- Extension Platform
- Non-Marking Rubber Crawler
- Automatic Brake System
- Emergency Descent System
- Emergency Stop Button
- Tubing Explosion-Proof System
- Fault Diagnosis System
- Tilt Protection System
- Buzzer
- Horn
- Safety Maintenance Support
- Standard Forklift Slot
- Charging Protection System
- Strobe Lamp
- Foldable Guardrail

选配配置

- 超载限制
- 底盘到平台AC电源
- 平台工作灯
- 底盘到平台导气管
- 平台防碰头开关

Optional Configuration

- Overload Sensor With Alarm
- AC Power On The Platform
- Platform Work Light
- Chassis-To-Platform Air Duct
- Top Limit Protection





5分钟响应答复
Response
Within 5-Minute



24小时内解决问题
Resolve Issues
Within 24Hours



48小时内发送配件
Send Parts
Within 48Hours

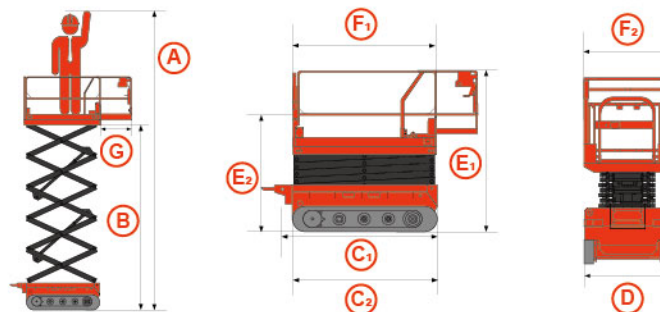

CFPT0407LD

产品参数 Product Parameters

安全工作载荷 Load Capacity	200Kg	最小转弯半径/最小离地间隙 Min. Turning Radius/Min. ground Clearance	0m/50mm
延伸平台安全工作载荷 Load Capacity Of Extended Platform	100Kg	起升电机 Lifting Motor	24V/1.2Kw
最大工作人数 Max. Number Of Workers	1	行走电机 Traveling Motor	2×24V/1.5Kw
最大工作高度 Max. Working Height	6.5m (A)	机器运行速度(收拢/起升) Machine Running Speed (Stowed/Raised)	1.7/0Km/h
最大平台高度 Max. Platform Height	4.5m (B)	上升/下降速度 Rising/Descending Speed	24/20sec
整机长度(含梯子) Overall Length (Including Ladder)	1340mm (C ₁)	蓄电池 Batteries	2×12V/120Ah
整机长度(不含梯子) Overall Length (Excluding Ladder)	1340mm (C ₂)	充电器 Charger	24V/15A
整机宽度 Overall Width	790mm (D)	最大爬坡能力 Gradeability	25%
整机高度(护栏未折叠) Overall Height (Guardrail Unfolded)	2105mm (E ₁)	工作最大允许角度 Max. Working Slope	1.5°/3°
整机高度(护栏折叠) Overall Height (Guardrail Folded)	1710mm (E ₂)	履带规格 Crawler Size	150×72mm
工作平台尺寸(长×宽) Platform Size(Length× Width)	1340×748mm (F ₁ × F ₂)	液压油箱容量 Hydraulic Oil Tank	3L
平台延伸尺寸 Platform Extension Size	600mm (G)	整机重量 Overall Weight	990Kg



CFPT0608LDN 6M

履带剪叉式升降平台 Crawler Scissors Lift Platform

标准配置

- 比例控制
- 平台门自锁
- 单向延伸平台
- 无痕橡胶履带
- 自动刹车系统
- 紧急下降系统
- 紧急停止按钮
- 油管防爆系统
- 故障诊断系统
- 倾斜保护系统
- 动作蜂鸣器
- 喇叭
- 安全检修支撑
- 标准运输叉车孔
- 充电保护系统
- 频闪灯
- 折叠围栏

Standard Configuration

- Proportional Control
- Self-lock Gate On Platform
- Extension Platform
- Non-Marking Rubber Crawler
- Automatic Brake System
- Emergency Descent System
- Emergency Stop Button
- Tubing Explosion-Proof System
- Fault Diagnosis System
- Tilt Protection System
- Buzzer
- Horn
- Safety Maintenance Support
- Standard Forklift Slot
- Charging Protection System
- Strobe Lamp
- Foldable Guardrail

选配配置

- 超载限制
- 底盘到平台AC电源
- 平台工作灯
- 底盘到平台导气管
- 平台防碰头开关

Optional Configuration

- Overload Sensor With Alarm
- AC Power On The Platform
- Platform Work Light
- Chassis-To-Platform Air Duct
- Top Limit Protection





5分钟响应答复
Response
Within 5-Minute



24小时内解决问题
Resolve Issues
Within 24Hours



48小时内发送配件
Send Parts
Within 48Hours

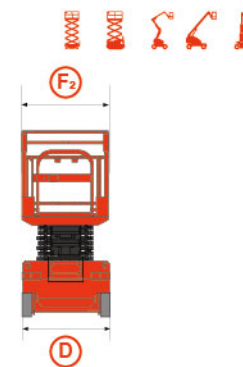
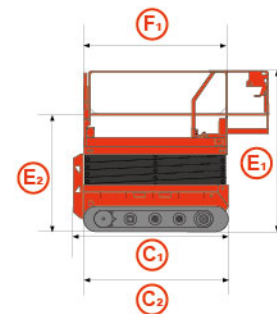
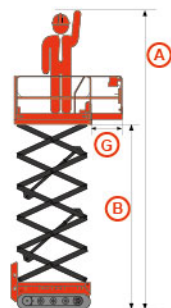

CFPT0608LON

产品参数 Product Parameters

安全工作载荷 Load Capacity	230Kg	最小转弯半径/最小离地间隙 Min. Turning Radius/Min. ground Clearance	0m/110mm
延伸平台安全工作载荷 Load Capacity Of Extended Platform	113Kg	起升电机 Lifting Motor	24V/1.2Kw
最大工作人数 Max. Number Of Workers	2	行走电机 Traveling Motor	2×24V/2.5Kw
最大工作高度 Max. Working Height	8m (A)	机器运行速度(收拢/起升) Machine Running Speed (Stowed/Raised)	2.4Km/h
最大平台高度 Max. Platform Height	6m (B)	上升/下降速度 Rising/Descending Speed	35/30sec
整机长度(含梯子) Overall Length (Including Ladder)	2056mm (C ₁)	蓄电池 Batteries	4×12V/300Ah
整机长度(不含梯子) Overall Length (Excluding Ladder)	1953mm (C ₂)	充电器 Charger	24V/30A
整机宽度 Overall Width	1030mm (D)	最大爬坡能力 Gradeability	25%
整机高度(护栏未折叠) Overall Height (Guardrail Unfolded)	2170mm (E ₁)	工作最大允许角度 Max. Working Slope	1.5°/3°
整机高度(护栏折叠) Overall Height (Guardrail Folded)	1815mm (E ₂)	履带规格 Crawler Size	200x72mm
工作平台尺寸(长×宽) Platform Size(Length× Width)	1859X810mm (F ₁ × F ₂)	液压油箱容量 Hydraulic Oil Tank	3L
平台延伸尺寸 Platform Extension Size	900mm (G)	整机重量 Overall Weight	1680Kg



CFPT0608LD 6M

履带剪叉式升降平台 Crawler Scissors Lift Platform

标准配置

- 比例控制
- 平台门自锁
- 单向延伸平台
- 橡胶履带
- 自动刹车系统
- 紧急下降系统
- 紧急停止按钮
- 油管防爆系统
- 故障诊断系统
- 倾斜保护系统
- 动作蜂鸣器
- 喇叭
- 安全检修支撑
- 标准运输叉车孔
- 充电保护系统
- 频闪灯
- 折叠围栏

Standard Configuration

- Proportional Control
- Self-lock Gate On Platform
- Extension Platform
- Rubber Crawler
- Automatic Brake System
- Emergency Descent System
- Emergency Stop Button
- Tubing Explosion-Proof System
- Fault Diagnosis System
- Tilt Protection System
- Buzzer
- Horn
- Safety Maintenance Support
- Standard Forklift Slot
- Charging Protection System
- Strobe Lamp
- Foldable Guardrail

选配配置

- 超载限制
- 底盘到平台AC电源
- 平台工作灯
- 底盘到平台导气管
- 平台防碰头开关
- 无痕橡胶履带
- 钢制履带

Optional Configuration

- Overload Sensor with Alarm
- AC Power On The Platform
- Platform Work Light
- Chassis-To-Platform Air Duct
- Top Limit Protection
- Non-Marking Rubber Crawler
- Steel Crawler





5分钟响应答复
Response
Within 5-Minute



24小时内解决问题
Resolve Issues
Within 24Hours



48小时内发送配件
Send Parts
Within 48Hours

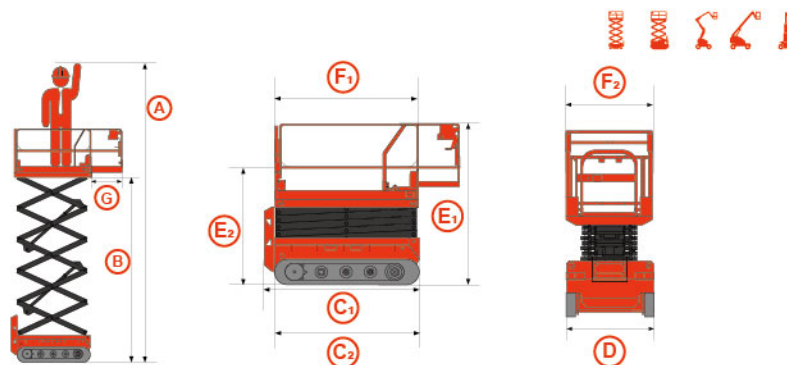

CFPT0608LD

产品参数 Product Parameters

安全工作载荷 Load Capacity	450Kg	最小转弯半径/最小离地间隙 Min. Turning Radius/Min. ground Clearance	0m/150mm
延伸平台安全工作载荷 Load Capacity Of Extended Platform	113Kg	起升电机 Lifting Motor	48V/4Kw
最大工作人数 Max. Number Of Workers	2	行走电机 Traveling Motor	2×48V/4Kw
最大工作高度 Max. Working Height	8m (A)	机器运行速度(收拢/起升) Machine Running Speed (Stowed/Raised)	2.0/0Km/h
最大平台高度 Max. Platform Height	6m (B)	上升/下降速度 Rising/Descending Speed	38/30sec
整机长度(含梯子) Overall Length (Including Ladder)	2470mm (C ₁)	蓄电池 Batteries	8×6V/200Ah
整机长度(不含梯子) Overall Length (Excluding Ladder)	2280mm (C ₂)	充电器 Charger	48V/25A
整机宽度 Overall Width	1390mm (D)	最大爬坡能力 Gradeability	30%
整机高度(护栏未折叠) Overall Height (Guardrail Unfolded)	2310mm (E ₁)	工作最大允许角度 Max. Working Slope	1.5°/3°
整机高度(护栏折叠) Overall Height (Guardrail Folded)	1750mm (E ₂)	履带规格 Crawler Size	300x72mm
工作平台尺寸(长×宽) Platform Size(Length× Width)	2270X1110mm (F ₁ × F ₂)	液压油箱容量 Hydraulic Oil Tank	20L
平台延伸尺寸 Platform Extension Size	900mm (G)	整机重量/整机重量(钢制履带款) Overall Weight/Overall Weight(Steel Crawler)	2520/2724Kg



CFPT0810LD 8M

履带剪叉式升降平台 Crawler Scissors Lift Platform

标准配置

- 比例控制
- 平台门自锁
- 单向延伸平台
- 橡胶履带
- 自动刹车系统
- 紧急下降系统
- 紧急停止按钮
- 油管防爆系统
- 故障诊断系统
- 倾斜保护系统
- 动作蜂鸣器
- 喇叭
- 安全检修支撑
- 标准运输叉车孔
- 充电保护系统
- 频闪灯
- 折叠围栏

Standard Configuration

- Proportional Control
- Self-lock Gate On Platform
- Extension Platform
- Rubber Crawler
- Automatic Brake System
- Emergency Descent System
- Emergency Stop Button
- Tubing Explosion-Proof System
- Fault Diagnosis System
- Tilt Protection System
- Buzzer
- Horn
- Safety Maintenance Support
- Standard Forklift Slot
- Charging Protection System
- Strobe Lamp
- Foldable Guardrail

选配配置

- 超载限制
- 底盘到平台AC电源
- 平台工作灯
- 底盘到平台导气管
- 平台防碰头开关
- 无痕橡胶履带
- 钢制履带

Optional Configuration

- Overload Sensor with Alarm
- AC Power On The Platform
- Platform Work Light
- Chassis-To-Platform Air Duct
- Top Limit Protection
- Non-Marking Rubber Crawler
- Steel Crawler





5分钟响应答复
Response
Within 5-Minute



24小时内解决问题
Resolve Issues
Within 24Hours



48小时内发送配件
Send Parts
Within 48Hours

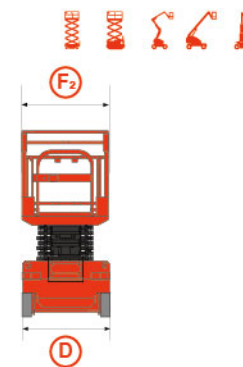
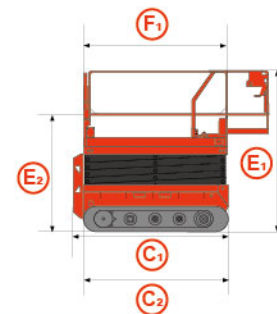
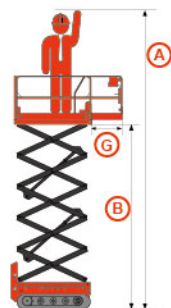

CFPT0810LD

产品参数 Product Parameters

安全工作载荷 Load Capacity	450Kg	最小转弯半径/最小离地间隙 Min. Turning Radius/Min. ground Clearance	0m/150mm
延伸平台安全工作载荷 Load Capacity Of Extended Platform	113Kg	起升电机 Lifting Motor	48V/4Kw
最大工作人数 Max. Number Of Workers	2	行走电机 Traveling Motor	2×48V/4Kw
最大工作高度 Max. Working Height	10m (A)	机器运行速度(收拢/起升) Machine Running Speed (Stowed/Raised)	2.0/0Km/h
最大平台高度 Max. Platform Height	8m (B)	上升/下降速度 Rising/Descending Speed	40/35sec
整机长度(含梯子) Overall Length (Including Ladder)	2450mm (C ₁)	蓄电池 Batteries	8×6V/200Ah
整机长度(不含梯子) Overall Length (Excluding Ladder)	2280mm (C ₂)	充电器 Charger	48V/25A
整机宽度 Overall Width	1340mm (D)	最大爬坡能力 Gradeability	30%
整机高度(护栏未折叠) Overall Height (Guardrail Unfolded)	2460mm (E ₁)	工作最大允许角度 Max. Working Slope	1.5°/3°
整机高度(护栏折叠) Overall Height (Guardrail Folded)	1905mm (E ₂)	履带规格 Crawler Size	300x72mm
工作平台尺寸(长×宽) Platform Size(Length× Width)	2270X1110mm (F ₁ × F ₂)	液压油箱容量 Hydraulic Oil Tank	20L
平台延伸尺寸 Platform Extension Size	900mm (G)	整机重量/整机重量(钢制履带款) Overall Weight/Overall Weight(Steel Crawler)	2670/2874Kg



CFPT1218RTE 12M

越野剪叉式升降平台

Electric Rough Terrain Scissor Lift Platform With Otriggers

标准配置 Standard Configuration

- | | | |
|--------------------------------|---------------------------------------|--|
| • 喇叭
Horn | • 倾斜警报
Tilt Alarm | • 负载传感系统
Load Sensing System |
| • 计时器
Timer | • 平台自锁门
Platform Self-locking Door | • 自重下降系统
Self Weight Descent System |
| • 频闪灯
Strobe Light | • 浮动桥底盘
Floating Bridge Chassis | • 油管防爆系统
Oil Pipe Explosion-proof System |
| • 应急下降
Emergency Descent | • 系索连接点
Lanyard Connection Point | • 故障诊断系统
Fault Diagnosis System |
| • 4x4驱动
4x4 Drive | • 双向延伸平台
Extension Platform | • 全比例手柄控制
Full Proportional Handle Control |
| • 行驶确认
Driving Confirmation | • 手动刹车释放
Manual Brake Release | • 无痕轮胎
Non-marking Tire |
| • 折叠围栏
Folding Fence | • 自动刹车系统
Automatic Brake System | • 固定和起重吊点
Fixed And Lifting Points |
| • 动作蜂鸣
Buzzer | • 紧急停止按钮
Emergency Stop Button | • 自动液压调平支腿
Automatic Hydraulic Leveling Support Leg |

选配配置

- 锂电池
- 1.83米工作栏
- 到平台AC电源线
- 限高防撞装置
- 平台加装工作灯

Optional Configuration

- Lithium Battery
- 1.83m Work Guardrail
- Platform AC Power Cord
- Top Limit Protection
- Platform Work Lights





5分钟响应答复
Response
Within 5-Minute



24小时内解决问题
Resolve Issues
Within 24Hours



48小时内发送配件
Send Parts
Within 48Hours

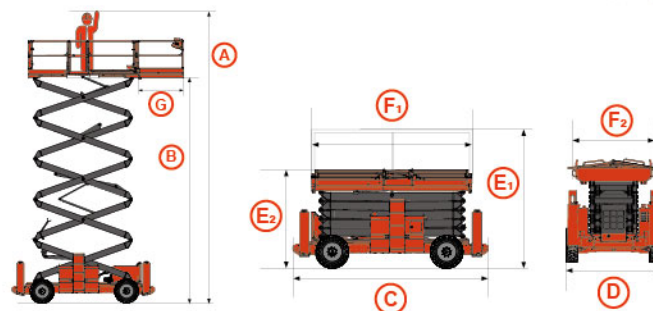

CFPT218ATE

产品参数 Product Parameters

安全工作载荷 Load Capacity	365Kg	最小离地间隙(收藏/起升) Min.Ground Clearance(Stowed/Raised)	0.16m
延伸平台安全工作载荷 Load Capacity Of Extended Platform	140Kg	机器运行速度(收藏/起升) Machine Running Speed(Stowed/Raised)	4.5/0.8Km/h
最大工作人数(室内/室外) Max. Number Of Workers(Indoor/Outdoor)	2/3	上升/下降时间 Rising/Descending Speed	60/50sec
最大工作高度 Max. Working Height	14m (A)	工作允许最大角度 Max.Working Slope	2°/3°
最大平台高度 Max. Platform Height	12m (B)	最大爬坡能力(空载收藏) Max.Gradeability	35%
整机长度(含梯子/不含梯子) Overall Length (Including/Excluding Ladder)	3.34/3.34m (C)	最大允许风速 Max.Allowable Wind Speed	12.5m/s
整机宽度 Overall Width	1.79m (D)	驱动型式 Drive Mode	4×4
整机高度(护栏未折叠/护栏折叠) Overall Height (Guardrail Unfolded/Folded)	2.77/2.11m (E1 / E2)	轮胎型式/规格 Type Of Tires/Tyre Size	Solid Tyre/Φ570×180mm
工作平台尺寸(长×宽) Platform Size(Length× Width)	2.91×1.53m (F1 × F2)	电池规格 Battery Specifications	8×6V/200Ah
平台延伸尺寸 Platform Extension Size	1.445m (G)	额定功率 Rated Power	4×1.8Kw+5Kw
轮距/轴距 Wheel Distance/Wheelbase	1.79/2.01m	液压油箱 Hydraulic Oil Tank	40L
最小转弯半径 Min.Turning Radius	4m	整机重量 Weight	4900Kg



CFPT1418RDE 14M

越野剪叉式升降平台

Electric Rough Terrain Scissor Lift Platform With Otriggers

标准配置 Standard Configuration

- | | | |
|--------------------------------|---------------------------------------|--|
| • 喇叭
Horn | • 倾斜警报
Tilt Alarm | • 负载传感系统
Load Sensing System |
| • 计时器
Timer | • 平台自锁门
Self-lock Gate On Platform | • 自重下降系统
Weight Drop System |
| • 频闪灯
Strobe Light | • 浮动桥底盘
Floating Axle Chassis | • 油管防爆系统
Tubing Explosion-proof System |
| • 应急下降
Emergency Descent | • 系索连接点
Lanyard Connection Point | • 故障诊断系统
Fault Diagnosis System |
| • 4x4驱动
4x4 Drive | • 延伸平台
Extension Platform | • 全比例手柄控制
Full Proportional Handle Control |
| • 行驶确认
Driving Confirmation | • 手动刹车释放
Manual Brake Release | • 无痕轮胎
Non-marking Tire |
| • 折叠围栏
Folding Fence | • 自动刹车系统
Automatic Brake System | • 固定和起重吊点
Fixing And Lifting Points |
| • 动作蜂鸣
Buzzer | • 紧急停止按钮
Emergency Stop Button | • 自动液压调平支腿
Automatic Hydraulic Leveling Leg |

选配配置

- 锂电池
- 1.83米工作栏
- 到平台AC电源线
- 限高防撞装置
- 平台加装工作灯

Optional Configuration

- Lithium Battery
- 1.83m Work Guardrail
- Platform AC Power Cord
- Top Limit Protection
- Platform Work Lights





5分钟响应答复
Response
Within 5-Minute



24小时内解决问题
Resolve Issues
Within 24Hours



48小时内发送配件
Send Parts
Within 48Hours

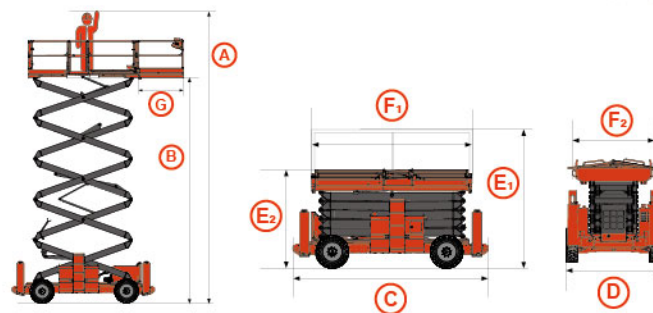

CFPT14180E

产品参数 Product Parameters

安全工作载荷 Load Capacity	320Kg	最小离地间隙(收藏/起升) Min.Ground Clearance(Stowed/Raised)	0.24m
延伸平台安全工作载荷 Load Capacity Of Extended Platform	140Kg	机器运行速度(收藏/起升) Machine Running Speed(Stowed/Raised)	4.5/0.8Km/h
最大工作人数(室内/室外) Max. Number Of Workers(Indoor/Outdoor)	2/3	上升/下降时间 Rising/Descending Speed	65/55sec
最大工作高度 Max. Working Height	16m (A)	工作允许最大角度 Max.Working Slope	2°/3°
最大平台高度 Max. Platform Height	14m (B)	最大爬坡能力(空载收藏) Max.Gradeability	35%
整机长度(含梯子/不含梯子) Overall Length (Including/Excluding Ladder)	3.34/3.34m (C)	最大允许风速 Max.Allowable Wind Speed	12.5m/s
整机宽度 Overall Width	1.79m (D)	驱动型式 Drive Mode	4×4
整机高度(护栏未折叠/护栏折叠) Overall Height (Guardrail Unfolded/Folded)	2.95/2.29m (E1 / E2)	轮胎型式/规格 Type Of Tires/Tyre Size	Solid Tyre/Φ660×250mm
工作平台尺寸(长×宽) Platform Size(Length× Width)	2.82×1.51m (F1 × F2)	电池规格 Battery Specifications	8×6V/200Ah
平台延伸尺寸 Platform Extension Size	1.445m (G)	额定功率 Rated Power	7.5Kw+4.5Kw
轮距/轴距 Wheel Distance/Wheelbase	1.79/2.01m	液压油箱 Hydraulic Oil Tank	40L
最小转弯半径 Min.Turning Radius	4m	整机重量 Weight	5560Kg



CFPT1623RTE 16M

越野剪叉式高空作业升降平台(电动款)
ELECTRIC ROUGH TERRAIN SCISSOR LIFT PLATFORM WITH OUTRIGGERS

标准配置 Standard Configuration

- 喇叭
Horn
- 计时器
Timer
- 频闪灯
Strobe Light
- 应急泵
Emergency Pump
- 4x4驱动
4x4 Drive
- 行驶确认
Driving Confirmation
- 折叠围栏
Folding Fence
- 动作蜂鸣
Buzzer
- 倾斜警报
Tilt Alarm
- 平台自锁门
Platform Self-locking Door
- 浮动桥底盘
Floating Bridge Chassis
- 系索连接点
Lanyard Connection Point
- 双向延伸平台
Bidirectional Extension Platform
- 手动刹车释放
Manual Brake Release
- 自动刹车系统
Automatic Brake System
- 紧急停止按钮
Emergency Stop Button
- 电池快慢充
Battery Charge Fast And Slow
- 负载传感系统
Load Sensing System
- 自重下降系统
Weight Drop System
- 油管防爆系统
Tubing Explosion-proof System
- 故障诊断系统
Fault Diagnosis System
- 全比例手柄控制
Full Proportional Handle Control
- 固定和起重吊点
Fixing And Lifting Points
- 自动液压调平支腿
Automatic Hydraulic Leveling Leg

选配配置

- 1.83米工作栏
- 平台加装工作灯
- 泡沫无痕轮胎
- 到平台AC电源线
- 限高防撞装置

Optional Configuration

- 1.83m Work Guardrail
- Platform Work Lights
- Foam Non-marking Tire
- Platform AC Power Cord
- Top Limit Protection





5分钟响应答复
Response
Within 5-Minute



24小时内解决问题
Resolve Issues
Within 24Hours



48小时内发送配件
Send Parts
Within 48Hours

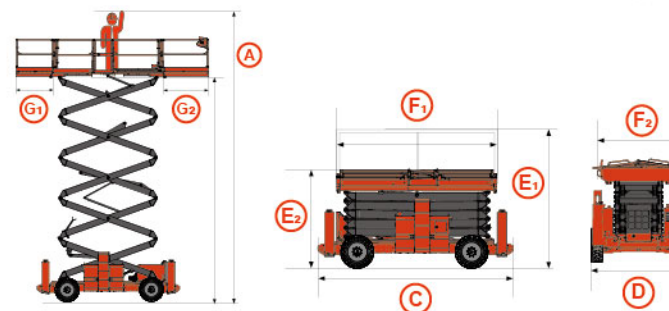

CFPT1623RTE

产品参数 Product Parameters

安全工作载荷 Load Capacity	680Kg	最小离地间隙(收藏/起升) Min.Ground Clearance(Stowed/Raised)	300mm
延伸平台安全工作载荷 Load Capacity Of Extended Platform	230Kg	机器运行速度(收藏/起升) Machine Running Speed(Stowed/Raised)	5.1/1.1Km/h
最大工作人数(室内/室外) Max. Number Of Workers(Indoor/Outdoor)	4/4	上升/下降时间 Rising/Descending Speed	55/70sec
最大工作高度 Max. Working Height	18m (A)	工作允许最大角度 Max.Working Slope	2°/3°
最大平台高度 Max. Platform Height	16m (B)	最大爬坡能力(空载收藏) Max.Gradeability	40%
整机长度(含梯子/不含梯子) Overall Length (Including/Excluding Ladder)	4.88/4.88m (C)	最大允许风速 Max.Allowable Wind Speed	12.5m/s
整机宽度 Overall Width	2.28m (D)	驱动型式 Drive Mode	4×4
整机高度(护栏未折叠/护栏折叠) Overall Height (Guardrail Unfolded/Folded)	3.27/2.52m (E1) / (E2)	轮胎型式/规格 Type Of Tires/Tyre Size	Solid Tyre/Φ835×290mm
工作平台尺寸(长×宽) Platform Size(Length× Width)	3.98×1.825m (F1) × (F2)	电池规格 Battery Specifications	77.8V/375Ah
平台延伸尺寸 Platform Extension Size	1.45/1.15m (G1) / (G2)	额定功率 Rated Power	18Kw+15Kw
轮距/轴距 Wheel Distance/Wheelbase	2.28/2.84m	液压油箱 Hydraulic Oil Tank	100L
最小转弯半径 Min.Turning Radius	6.55m	整机重量 Weight	8380Kg



CFPT1623RTD 16M

越野剪叉式高空作业升降平台 ROUGH TERRAIN SCISSOR LIFT PLATFORM WITH OUTRIGGERS

标准配置 Standard Configuration

- 喇叭
Horn
- 倾斜警报
Tilt Alarm
- 负载传感系统
Load Sensing System
- 计时器
Timer
- 平台自锁门
Platform Self-locking Door
- 自重下降系统
Weight Drop System
- 频闪灯
Strobe Light
- 浮动桥底盘
Floating Bridge Chassis
- 油管防爆系统
Oil Pipe Explosion-proof System
- 应急泵
Emergency Pump
- 系索连接点
Lanyard Connection Point
- 故障诊断系统
Fault Diagnosis System
- 4x4驱动
4x4 Drive
- 双向延伸平台
Bidirectional Extension Platform
- 全比例手柄控制
Full Proportional Handle Control
- 行驶确认
Driving Confirmation
- 手动刹车释放
Manual Brake Release
- 液压油散热系统
Hydraulic Oil Cooling System
- 折叠围栏
Folding Fence
- 自动刹车系统
Automatic Brake System
- 固定和起重吊点
Fixing And Lifting Points
- 动作蜂鸣
Buzzer
- 紧急停止按钮
Emergency Stop Button
- 自动液压调平支腿
Automatic Hydraulic Leveling Leg

选配配置

- 锂电池
- 1.83米工作栏
- 泡沫无痕轮胎
- 限高防撞装置
- 平台加装工作灯
- 到平台AC电源线

Optional Configuration

- Lithium Battery
- 1.83m Work Fence
- Foam Non-marking Tire
- Top Limit Protection
- Platform Work Lights
- To Platform AC Power Cord





5分钟响应答复
Response
Within 5-Minute



24小时内解决问题
Resolve Issues
Within 24Hours



48小时内发送配件
Send Parts
Within 48Hours

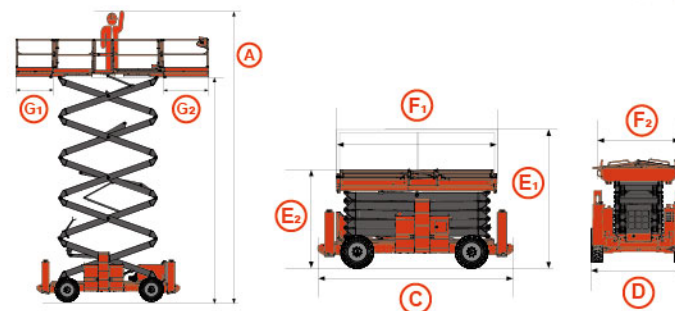

CFPT1623RTD

产品参数 Product Parameters

安全工作载荷 Load Capacity	680Kg	最小离地间隙(收藏/起升) Min.Ground Clearance(Stowed/Raised)	220mm
延伸平台安全工作载荷 Load Capacity Of Extended Platform	230Kg	机器运行速度(收藏/起升) Machine Running Speed(Stowed/Raised)	6.1/1.1Km/h
最大工作人数(室内/室外) Max. Number Of Workers(Indoor/Outdoor)	4/4	上升/下降时间 Rising/Descending Speed	55/55sec
最大工作高度 Max. Working Height	18m A	工作允许最大角度 Max.Working Slope	2°/3°
最大平台高度 Max. Platform Height	16m B	最大爬坡能力(空载收藏) Max.Gradeability	40%
整机长度(含梯子/不含梯子) Overall Length (Including/Excluding Ladder)	4.87/4.87m C	最大允许风速 Max.Allowable Wind Speed	12.5m/s
整机宽度 Overall Width	2.28m D	驱动型式 Drive Mode	4×4
整机高度(护栏未折叠/护栏折叠) Overall Height (Guardrail Unfolded/Folded)	3.17/2.41m E_{1/2}	轮胎型式/规格 Type Of Tires/Tyre Size	Solid Tyre/Φ835×290mm
工作平台尺寸(长×宽) Platform Size(Length× Width)	3.94×1.8m F_{1×2}	发动机型号 Engine model	KubotaV2403
平台延伸尺寸(前/后) Platform Extension Size(Front/Back)	1.45/1.15m G_{1/2}	额定功率 Rated Power	18Kw+15Kw
轮距/轴距 Wheel Distance/Wheelbase	2.28/2.84m	液压油箱 Hydraulic Oil Tank	100L
最小转弯半径 Min.Turning Radius	5.33m	整机重量 Weight	8380Kg



CFCA16RE 15.7M

曲臂式高空作业升降平台 Articulated Boom Lift

标准配置

- 泡沫轮胎
- 主臂自重下降
- 160°液压旋转平台
- 铅酸电池
- 紧急制动解除
- 旋转报警灯安全警示
- 称重系统
- 故障诊断系统
- 后方检测和行驶确认
- 显示屏幕
- 紧急停止系统
- 全比例手柄渐变控制
- 力士乐系统
- 紧急下降系统
- 液压调平的工作平台
- 355°转台旋转
- 倾斜保护系统
- 喇叭和蜂鸣器安全警示
- 最大允许 5°工作倾角

Standard Configuration

- Foam Tyre
- Main Arm Weight Drop
- 160° Hydraulic Rotary Platform
- Lead-acid Battery
- Emergency Brake Release
- Rotating Alarm Light Safety Warning
- Weighing System
- Fault Diagnosis System
- Rear Detection And Ride Confirmation
- Display Sscreen
- Emergency Stop System
- Full Scale Lever Gradient Control
- Rexroth System
- Emergency Descent System
- Hydraulically Levelled Work Platform
- 355° Turntable Rotation
- Tilt Protection System
- Horn And Buzzer Safety Warning
- Max.allowable Operating Inclination Of 5°

选配配置

- 锂电池
- 限高防撞装置
- 1.83米工作栏
- 平台加装工作灯
- 泡沫无痕轮胎
- 到平台 AC 电源线

Optional Configuration

- Lithium Battery
- Top Limit Protection
- 1.83 m Working Bar
- Platform Fitted With Working Lights
- Foam Seamless Tires
- AC Power On The Platform





5分钟响应答复
Response
Within 5-Minute



24小时内解决问题
Resolve Issues
Within 24Hours



48小时内发送配件
Send Parts
Within 48Hours

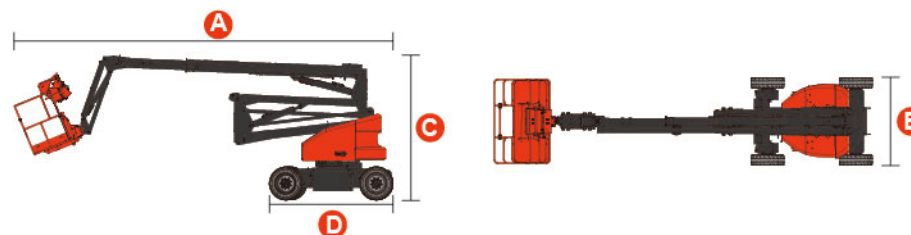

CFCA16AE

产品参数 Product Parameters

最大平台高度 Max. platform Height	15.7m	最高行驶速度-收起状态 Max. horizontal Extension	5.2km/h
最大作业高度 Max. operating Height	17.7m	最高行驶速度-举升状态 Max. spanning Height	0.8km/h
最大水平延伸 Max. horizontal Extension	9.3m	爬坡能力 Length-retracted State	30%
最大跨越高度 Max. spanning Height	7.8m	内转向半径 Width-retracted State	0.7m
长度-收起状态 Length-retracted State	6.8m (A)	外转向半径 Height-retracted State	3.31m
宽度-收起状态 Width-retracted State	1.9m (B)	转台尾扫 Wheelbase	50mm
高度-收起状态 Height-retracted State	2m (C)	工作时允许倾角 Ground Clearance	5°
轴距 Wheelbase	1.9m (D)	驱动×转向 Platform Size (Length × Width)	2WDx2WS
离地间隙 Ground Clearance	0.22m	轮胎规格/类型 Platform Size (Height)	240/55D17.5Foam Tyre
平台尺寸(长×宽×高) Platform Size (Length × Width)	1.45m×0.85m×1.1m	电池规格 Battery Specifications	8×6V,420Ah
额定承载(不受限/2人及工具) Platform Size (Height)	230kg	控制电压 Control Voltage	12V DC
转台回转 Max. platform Height	355°	液压油箱容积 Hydraulic Oil Tank Capacity	40L
平台回转 Max. operating Height	160°	整机重量 Weight	7,300kg



CFSA22RE 22.5M

直臂式高空作业升降平台 Telescopic Boom Lift

标准配置

- 全时浮动
- 四轮刹车
- 称重系统
- 语音播报
- 平台旋转
- 7寸智慧屏
- T-BOX(GPS)
- 四轮驱动/两轮转向
- 汽车级全管护套保护
- 三手柄渐变比例控制
- 最大允许5°工作倾角
- 后方检测和行驶确认
- 旋转报警灯安全警示
- 喇叭和蜂鸣器安全警示
- 应急下降系统
- 故障诊断系统
- 倾斜保护系统
- 紧急停止系统
- 工作平台液压调平
- 行走制动机械解除

Standard Configuration

- Full-time Float
- Four-wheel Brake
- Weighing System
- Voice Broadcast
- Platform Rotation
- 7 Inch Smart Screen
- T-BOX(GPS)
- Four-wheel Drive/Two-wheel Steering
- Automotive Grade Full Tube Sheath Protection
- Three Handle Gradient Proportional Control
- Maximum Allowable Operating Inclination Of 5°
- Rear Detection And Ride Confirmation
- Rotating Alarm Light Safety Warning
- Horn And Buzzer Safety Warning
- Emergency Descent System
- Fault Diagnosis System
- Tilt Protection System
- Emergency Stop System
- Hydraulic Leveling Of Work Platform
- Walking Brake Mechanical Release

选配配置

- 文件盒
- 锂电池
- 防撞装置
- 铅酸电池
- 无痕轮胎
- 实心轮胎
- 平台工作灯
- 防夹人装置
- AC电源线至平台
- 工具箱(限旋开门工作栏)
- 半高围栏(限旋开门工作栏)
- 玻璃支架(限旋开门工作栏)

Optional Configuration

- Tool Box
- Lithium Battery
- Anti-collision Device
- Lead-acid Battery
- Non-Marking Tyre
- Solid Tyre
- Platform Working Light
- Anti-pinch Device
- Platform AC Power Cord
- Tool Box(Limited Revolving Door Workbench)
- Half-height Fence(Limited Revolving Door Workbench)
- Glass Support(Limited Revolving Door Workbench)





5分钟响应答复
Response
Within 5-Minute



24小时内解决问题
Resolve Issues
Within 24Hours



48小时内发送配件
Send Parts
Within 48Hours

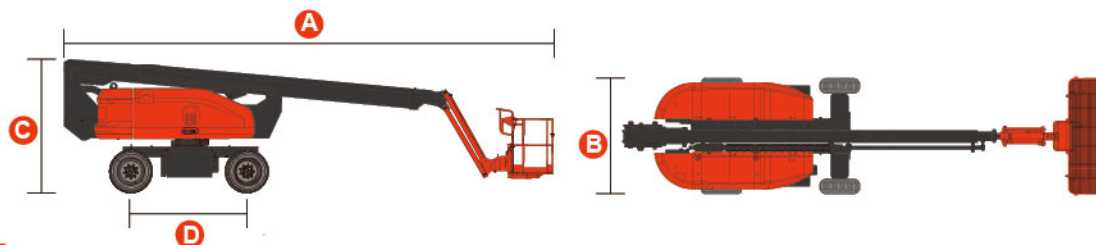

CFS222AE

产品参数 Product Parameters

最大平台高度 Max. platform Height	22.5m	转台回转(角度/连续性) Turntable Rotation (Angle/Continuity)	360°/Continuous
最大作业高度 Max. operating Height	24.5m	平台回转角度 Platform Rotation Angle	160°
最大水平延伸(受限/不受限) Max. horizontal Extension (Restricted/Unrestricted)	12.7m/14.3m	最大允许倾角 Max. allowable Tilt Angle	5°
最大水平作业幅度(受限/不受限) Max. horizontal Working Amplitude (Restricted/Unrestricted)	13.3m / 14.9m	转弯半径(内轮) Turning Radius (Inner Wheel/Outer Wheel)	2.4m
整机长度(收车状态) Overall Length (Retracted State)	10.68m A	转弯半径(外轮) Turning Radius (Inner Wheel/Outer Wheel)	5.55m
整机宽度(收车状态) Overall Width (Retracted State)	2.49m B	转台尾扫 Turntable Tail Sweep	1.45m
整机高度(收车状态) Overall Height (Retracted State)	2.81m C	最大允许侧向力 Max. allowable Lateral Force	400N
轴距 Wheelbase	2.49m D	最大允许风速 Max. allowable Wind Speed	12.5m/s
离地间隙 Ground Clearance	0.39m	轮胎规格/类型 Tire Specifications/Type	355/55D625(Foam Tyre)/36×14-20(Solid Tyre)
平台尺寸(长×宽×高) Platform Size (Length x Width)	2.44m×0.91m×1.1m	驱动×转向 Drive × Steering	4WD×2WS
平台额定承载能力(受限/不受限) Rated Load Capacity (Restricted/Unrestricted)	454kg/300kg	液压油箱容量 Hydraulic Oil Tank Capacity	180L
平台最大承载人数(受限/不受限) Ma. number Of People On The Platform (restricted/unrestricted)	3/2	电池规格(电压,容量) Battery Specifications (Voltage, Capacity)	48V,480Ah(Lead Acid)/48V,528Ah(Lithium Battery)
行驶速度(收车状态)/(举升状态) Driving Speed (Retracted State)/(Lifting State)	0~4.8km/h/0~1.1km/h	充电器(输入电压/输出电流) Charger (Input Voltage/Output Current)	100~240V AC/40A
爬坡能力(4WD) Climbing Ability (4WD)	35%	整机重量 Weight	12260kg